

im print

p2

MEET YOUR CANDIDATES

Read about this year's Feds election candidates to prepare for the election.



WINTER INVITATIONALS

Warriors attend Figure Skating Winter Invitational hosted by Ontario University Athletics. **P16**

COMMUNITY QUILTS P13

Conrad Grebel University College strengthens fabric of UW relationships.

DONNA STRICKLAND STRIKES AGAIN P11

Nobel Laureate speaks at University of Waterloo's President's Lecture.

WARRIORS WIN AGAIN P15

The women's volleyball team face off against McMaster Marauders.

Imprint hosts Feds candidates debate P9



news

WRITE FOR NEWS
Imprint is looking for news writers.
Email editor@uwimprint.ca

GET INVOLVED
Imprint is looking for a community-minded
Arts Editor. Email editor@uwimprint.ca.

WWW.UWIMPRINT.CA
Check the web for all the latest campus and
community news.

Feds elections: Meet your candidates

Harleen Kaur Dhillon
Editorial Assistant

Feds executive team is getting a reboot for their next term. Feds



Matthew Gerrits,
re-election

I chose to run for this position because being in this role this year has shown me the amazing things that advocacy can achieve. There are a lot of projects still in motion, and government relations are going to be critical this year. I think my ability to hit the ground running is going to be a big asset in working on these projects.

Some of my bigger



Fayza Ibrahim, Team Gold

I have chosen to run for VP Education because I believe education should be accessible. Having worked with the Federation of Students as a promotional representative, I have learned more about students' needs, as well as the barriers in

General Elections are set to start at 10 a.m. on Feb. 5 and last until Feb. 7.

There are four roles up for grabs: VP Operations and Finance, VP Education, VP Student Life, and President.

VP Education

on-campus goals this year are 1) Pushing for a campus-wide syllabus repository, which would require buy-in from each faculty to expand on a system currently in development under Math. 2) Establishing a campus advisory group on academic advisers. If the Student Success Office doesn't agree to make an advisory group, although I think they would, it could be a group that Feds puts together itself. 3) Campus guidelines on verification of illness forms/accommodations for mental illness. I will make sure that these become enforceable university guidelines rather than just a best-practices document. I think the biggest issue would have to be the recent government announcement on post-secondary education fundings.

place of attaining education. I want to be able to make real change for our campus and set a precedent for a better future.

I have three major goals for the term. First, I am advocating to all levels of government in Canada to help reduce financial barriers in education. Second, I plan to advocate for our students to receive open educational resources. Finally, I want to aid students in receiving more support from their instructors regarding any concerns to their mental health and well-being. I believe an important issue to address is mental health of students. It is important for

The following students are candidates who are working to better student experiences, life, clubs and services at UW in their own ways.

Vote for your representatives at vote.feds.ca.

To tackle the OSAP issue, I would make student financial aid the top Feds priority on federal advocacy. What I would do differently, federally, is be open to compromise to move the tax credits from non-refundable to refundable.

Continuity is hugely important in this role. There are still ongoing projects related to my predecessor, for example, a permanent fee governance model for the co-op fee, and changes to teaching evaluations on campus. I've already hired a staff member dedicated to the Centre for Academic Policy Support. Upcoming changes will focus on more outreach to students and more use of formal submissions on provincial and federal budgets.

See Matt's full platform at vpedmatt.com.

students to be aware of the extent of what their Feds health plan covers externally, pertaining to counselling and psychiatric treatments. Additionally, I believe that we need more programming in place that address sustainable self care.

I would like to continue involvement with OUSA as previous executives have. I want to contribute to reviving student engagement on our campus, through a more interactive and collaborative experience.

I firmly believe that if students see their ideas incorporated on policy platforms, they are more likely to be engaged.



Tomson Tran, Team Ignite

I want to give back to student life and help it evolve for the best of the students. Every day I see the impacts of how student life changes their experience here at UW.

Throughout my undergraduate studies, I have accomplished so much by being involved continuously.

For the past three years, I have been involved with Feds as a Councillor, as a Board member, and am lucky to witness still and take part in knowing how complicated student life is. Within AHSUM I've grown from a Councillor to now being the President.

Next, as a Senator, I was able to advocate for stu-



Amanda Fitzpatrick,
Team Gold

Throughout my undergrad I have worked to advocate on behalf of students to make our campus a more accepting and equitable place. I believe my experience as Glow coordinator and my other various volunteer roles on campus have given me insight into student

VP Student Life

dents at the highest educational governing body. This led to monthly reports with Provost Rush, previously known as Dean Rush, where we would discuss faculty and university-level changes. As well, on Senate, [I advocated for] passing policies to improve the experience of sexual assault and harassment survivors on campus.

One of the main goals I will be focusing on with my team is mental health and wellness.

We would love to change the discourse of mental health and wellness here at UW. Asking for help should not be the last resort. Resources should be more apparent and accessible to everyone.

This would involve lobbying Question, Persuade, and Refer training for all University staff and faculty as well as student leaders.

Then, we would want to expand the network of mental health support to the university communi-

ty to further improve the treatment of students.

With Team Ignite, one of our main goals is to help with mental health and wellness. We understand that this is a problem all across Canada. Together Team Ignite can better support students here at UW in this avenue. What I would focus on in my individual portfolio would be the following: stronger support for MATES (Mentor Assistance Through Education and Support), student leaders, and finally, community building on our campus.

My predecessor, Savannah Richardson, has been focusing on improving many relationships on campus. I would continue to strengthen the ties within Feds and the university. She has taken many initiatives to visit the Satellite campuses and to hear their concerns.

I wish to make sure all parts of Feds feel supported and continue to strengthen those relationships.

needs as well as knowledge about initiatives already running on campus. Most importantly my passion for inclusion and accessibility will be assets in this role.

One of my main goals is to ingrain equity and sustainability into how Feds runs. Working together with the services to create more collaborative events as well as support them to reach their goals will be a huge priority.

Student mental health has been one of the main focuses of [Team Gold's] platform. One of the ways I wish to combat this is by creating a comprehensive student life/mental health resource that matches students with

all of the clubs, services, and resources that are available on and off campus. By narrowing down what is applicable to each student it will be less intimidating to search for resources and participate in student life.

One objective the current VPSL started up that I would like to continue is the coordinator committee. I think it would be incredibly valuable to improve communication between services and work on more collaborative events. However, due to the different types of services that Feds offers I think it would be helpful to have separate committees for operational services and equity services.

President

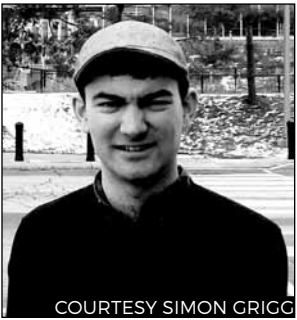

COURTESY SIMON GRIGG

Simon Grigg, Team C-Soc

I chose to run because I had enough nominations. I am the ideal candidate because I was eligible to run.

My primary goal for the term is, for the fifth time, try to get through Infinite Jest. I'm not sure that it's possible, but I'm going to try.

We have too many Feds services. I will tackle it by merging Feds services with

each other.

The current Exec is trying to merge MATES and the foodbank.

I'm going to take that one step further and merge each service with another service.

Unlike my predecessors, I will make trying to read Infinite Jest a priority. Expect updates on my attempts to read Infinite Jest.

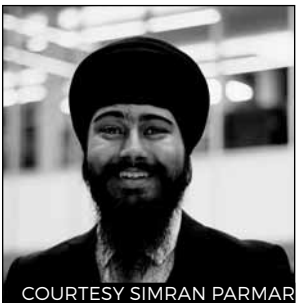

COURTESY SIMRAN PARMAR

Simran Parmar, Team Gold

Our entire platform has been formed through student consultation to ensure we are tackling the issues which require the most amount of attention. We have also met with both Feds and university staff to understand the process behind fulfilling our promises and ensuring our plans are feasible.

The disconnect between Feds governance and the student body and the overall disconnect between faculties across the University is an immense issue. It is

I would like to use the skills that I have developed as a promo team member to reconnect Feds Governance with the student voice.

time for us to create a greater unity amongst this campus.

As president, I will be highly focused on continuing the previous executive team's work on mental health.

Our team would like to have more diverse [mental health] counsellors hired and a better matching system between students and counsellors. We will try to fix some of the upstream issues because we all know that it is better to prevent an issue before it occurs.



COURTESY M. BEAUCHEMIN

Michael Beauchemin, Team Ignite

I chose to run for the President position in Feds because I like working with students. I am incredibly passionate about helping people, and well-organized. I have developed an appreciation of and desire to do advocacy work for students, with respect to academics, mental health, social life, and more.

For the 2019-2020 year would like to expand the student mental health support network to the community and embed support within the student body. I would like to lobby the government for more mental health funding to the Region of Waterloo to support the system and enable it to support referrals from the

university better.

Students have a right to access information on how their fees are used. This can be accomplished by providing a secure environment for students to view sensitive information. Also, I would like to generate opportunities for engagement between students and their representatives and governing bodies, and encourage good working relationships between staff and student representatives.

The most important issue facing UW students right now is a feeling of social exclusion and the mental health issues that arise from that. The same also occurs in reverse, with the stigma and discrimination surrounding mental health. I find that there's often not discrimination against people with mental illness, but rather that these people will stigmatize their own experiences, even if they are very tolerant and understanding of other people's situations.

I can bring this forward to the Committee on Student Mental Health, to the more than 70 peer support groups

on campus, including Feds' own MATES, and exert pressure on the university to reform its practices (including a review of Policies 70-72 to make them serve students better and treat them as more than miscreants). I also want to encourage the SSO and counselling to run more question, persuade, and refer, more feet on the ground, and mental health first aid training, and to target student leaders (like Society exec, O-Week leaders, and Peer Mentors) for these. I am really excited to continue to represent students and their concerns. I will also take an active role in sharing information from the committee with students. My predecessor made other things a priority but I will be prioritizing the student voice on this and other committees. An example of something I want to change from my predecessor is the executive structure. Right now, it's treated as a horizontal hierarchy, but that just leads to accountability issues, so if I'm elected the VPs will report to me as the president.

VP Operations and Finance



COURTESY SENECA VELLING

Seneca Velling, Team Ignite

I believe in the power of making change. Over the last two years I've worked hard to represent science students as a science councillor and increase engagement. I'd like to bring the same spirit to my work as VPOF.

I want to do a deep-dive review into [the] \$169/term mandatory non-refundable student services fee which funds CCA, Health Services, Counselling Services, Athletics & Recreation, the Writing Centre and more. I will work to make budgets public and release more information to students.

Team Ignite will conduct a review of the environmental practices of Feds and the societies to create a sustainability report and set improvement benchmarks and make sure the university is meeting their strategic targets. I will ensure Feds phases out all styrofoam from use, and minimizes single-use plastics. I will also work with the university to expand the collection of organics for composting and expand the Sustainable Campus Initiative's campus garden and farm spaces. [I also hope to create a] student soup kitchen for excess food from Feds, the societies, and UWFS businesses.

[We] are pushing to create a tenancy and rental database like a UW Flow type website accessed through CAS-login for rating off-campus housing, tenancy corporations, and landlords to increase awareness about predatory groups and see other students' experiences! I've had the pleasure of working with Kurt

on a number of things this past year — from increasing accessibility of services like UPASS for part-time students with disabilities, to ensuring student consultations determine the direction of the Bomber, to making sure all corporate budgets get vetted by a student committee (the budget and appropriations Committee) — I intend to continue these projects when elected. On UPass specifically, I am very excited for the part-time student UPass referendum. If that passes as VP Operations & Finance I will be overseeing expansion of the service.

I intend to push for all commercial operations budgets to be public and vetted by the budget and appropriations Committee. I think more diligent review, approval, and long-term planning is essential to make sure Feds is a viable, successful, and forward-looking student advocacy organization for years to come!



COURTESY JOSHUA MBANDI

Joshua Mbandi, Team Gold

I chose to run for Feds as VP Operations and Finance because I realized Feds was becoming increasingly disconnected from the needs of students, and I wanted to help solve that, and other issues including lack of student engagement and a disconnect between the leaders in Feds governance bodies and the student body. I believe I have the necessary balance of managerial capabilities, Feds governance experience, and a connection to the student body through my involvement with various clubs that will allow me to effectively accomplish the tasks Team Gold believes should be achieved.

As VP Operations and Finance, I will oversee the

Bombshelter revitalization with an increased and expanded emphasis on student consultation and commercial viability, and seek to ensure that the new Bombshelter space is renovated with expanded student input and consultations on what the new space should include, as well as work with the necessary internal and external partners to expand the food options on campus.

I will work with my fellow execs to protect funding to vital Feds services like MATES/Food Bank, and the Womens' Centre while seeking to ensure these services continue to be responsive to student needs as well as work with the necessary partners including the VP Student Life and General Manager to improve the financial management of Feds clubs by instituting online forms submissions, online reimbursements for clubs, as well as streamlining processes around club's management to ensure operational effectiveness and responsiveness.

I believe protecting and

enhancing funding to vital mental health resources provided by Feds services, like peer support services and the Food Bank, are vital.

I will work to protect funding for Feds services from cuts, and ensure they're able to provide the necessary peer support and mental health assistance services that they provide the student body, as these services are necessary to student life.

I believe the current VP Operations and Finance deserves the necessary credit for working with councillors to bring forward the referendum on a legal aid service that would provide students with vital legal aid services that are desperately needed. I believe students deserve legal protection against the predatory practices of housing companies. As VP Operations and Finance, pending the approval of the referendum, I will work to ensure the legal aid service is effectively implemented and available to students to ensure they have access to vital legal support.

?? ? Campus Question ?? ?

See what students think about current issues

This week: Do you think the recent polar vortex we experienced, is a sign of a climate emergency?



**Aaron Herschberger, 1B
Physics**

"No. I just think whatever way the weather shifts, we will make do. Personally, I don't think there is so much we can do as a country because most of the biggest contributors to climate change are not Canada, and [the contributors] don't really believe in global warming. We can help a little, but I don't think it will make a big impact."



**Holden Wu, 3B
Psychology**

"I would say no. I think it's normal. Like it's cold, then it will get warm, then it will get cold again. The last couple of years have been like that. I do think there is an issue with the climate, with global warming, and stuff like that. I just think it's been pretty weird this year. I am sure we'll be alright."



**Noor Adi, 4B
Honours Science**

"It's hard to say because I feel like it happens every year. I feel like yes, climate change is definitely happening, but I also feel like it's normal. And it was only a couple of days, I would have been more worried if the bad weather lasted more than a week. In Canada, that is pretty normal."



**Vicky Vuong, 4B
Biomedical Science**

"I think the biggest issue is that people don't address it enough. A lot of people know it exists and [most people] believe it's true. But the thing is, I don't think people care enough about it. But I do think that this crazy weather [that's] going on is because of climate change. It's definitely more than just 'a warming.' This is a result of progressing issues."

PHOTOS VISHAL LILMAN

WANT A CAREER IN THE ARTS?

WE SHOW YOU HOW

ONTARIO GRADUATE CERTIFICATES

- Arts Administration and Cultural Management
- Creative Book Publishing
- Creative Writing - Fiction, Creative Non-Fiction, Poetry
- Music Business
- Music Composition
- Television Writing and Producing

*David Albertyn, Humber
Creative Writing Graduate and
Author of Undercard (House of
Anansi Press, 2019)*



creativearts.humber.ca/gradstudies

Waterloo Region water pipes leak with dropping temperatures

University of Waterloo finding innovative solutions to detecting leaks and fixing them

Kate Yeardon and Charlotte Hings
Reporter, Managing Editor

University of Waterloo researchers help cities listen for water pipe leaks using artificial intelligence (AI) equipped fire hydrants called hydrophones. “They could be more proactive as opposed to reactive,” Roya Cody, lead researcher, said.

Small leaks in municipal water pipelines often run for years without detection. Cody’s team plans to catch leaks as they appear using the hydrophones.

Hydrophones use machine



CIPP liner being installed.

learning algorithms to pick up the acoustic signature of water leaking out of pipes. Hydrophones placed inside water supply pipes monitor flowing water by listening for the tell-tale sounds of leaks. These inexpensive sensors are installed through municipal fire hydrants without affecting the hydrant’s functionality.

Water pipe leaks account for huge losses of water. Over 13 per cent of water in Canadian municipal water systems is lost due to leaks, bursts, and the resulting problems. The amount of water wasted increases in municipalities with less developed pipelines. “[Hydrophones] would allow cities to use their resources for maintenance and repairs much more effectively,” Cody said.

The project also reduces health hazards and saves municipalities from incurring additional costs. Unsafe contaminants enter water supplies through leaks in water pipes, and continuous leaking also deteriorates buildings and infrastructure over time.

“By catching small leaks early, we can prevent costly, destructive bursts later on,” Cody said. Tests run inside the lab using PVC pipes and fire hydrants detect leaks as

little as 17 liters per minute. Leaks of this size generally go unnoticed. The research group has moved on to in-field testing. The team hopes to work out how to determine the exact location of leaks in this phase. Their work will allow municipalities to identify and prioritize repairs. While catching pipe leaks early is certainly important, fixing them is equally so. With the recent cold snaps and dropping temperatures, more water main pipe leaks and breaks are expected in the Waterloo region. The colder, more sustained temperatures drive frost lower into the ground, where the pipes are. This can cause movement of the placement of the pipes as well as contraction of the metal pipes, which will later expand when the weather warms.

A think-tank at the University of Waterloo has come up with a new innovative solution for fixing these water pipes called cured in place pipe (CIPP).

“We are building new pipes inside the old pipes using the old pipe as a form,” Mark Knight, a member of the think-tank, said. This concept involves shooting a lining into the existing pipes, curing it so that it hardens into a new pipe inside the old pipe. This is not

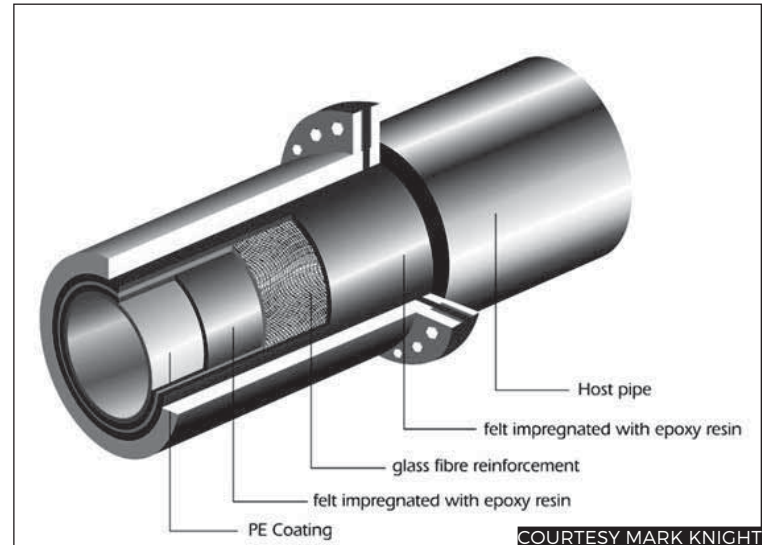

Design of a new CIPP liner that is formed inside the old iron water main pipe.

considered a band-aid solution but an actual long-term sustainable solution.

The City of Waterloo has 400 km of piping made up of mostly cast iron or ductile iron piping, which typically have a life of about 100 years.

“This means that they need to replace about four km per year,” Knight said.

While this would add about 100

years to the life of the pipes, it is a costly procedure. However, it is important that cities remain proactive about their water pipes. Otherwise, there will come a time when they will be forced to act and replace the pipes, regardless of finances. “We are also developing tools to help water utilities development programs and to get funding to fix these aging and deteriorated water pipes,” Knight said.

GIVEAWAY

1. FOLLOW @UWIMPRINT

2. TAG A FRIEND

3. COMMENT YOUR FAVOURITE WINTER DRINK

SPECIAL SAVINGS

20% discount

off your next purchase at one of our locations

can not be combined with other offers * one coupon per purchase * no direct cash value * customer pays applicable taxes * terms and conditions apply * expires February 28/19

Locally Owned & Operated Business Offering

FRESH MEALS

WATERLOO

160 University Ave., W. & 220 King Street, N.

www.shawerma.com

Make your house the Grad House



The Grad House offers a calm environment to relax, eat and drink after a long week of hard work.

Charlotte Hings
Managing Editor

The closing of the Bomber means that there is now a lack of space for undergrad

students; however, the Grad House can be a viable option for those looking for a space on campus. The Grad House is predominantly meant as a social space for graduate students, offering a calm environment to relax, eat, and drink

after a long week of hard work. It is currently the only designated space for graduate students, but undergrads are welcome as well.

The Grad House is prepared to receive a larger influx of traffic, in their welcoming of all undergrads. However, it is a licensed establishment so any students visiting the Grad House for an alcoholic beverage must be 19 or older.

Undergrads are also not able to access the discounted pricing afforded to grad students who have paid the Grad House fee. The Graduate Student Association is ensuring that the extra traffic does not prevent Grad students from using the space.

The Grad House provides locally sourced, quality food and beverages with 15 draft taps of locally produced craft beers and ciders. Food is made in-house as much as possible, from the salad dressings to the 100 per cent beef burgers.

Their chicken is hand-cut halal from Sargent farms in Milton, and their tempeh comes from Henry's Tempeh in Kitchener. Even more exciting, a new menu has just been



Jannat Hundal, a master's candidate in engineering, enjoying lunch and a midday coffee at the Grad House.



Their chip and dip (left) makes a great light and refreshing snack. Their chili (right), is the perfect meal for a cold winter day.

launched this past month featuring new vegan and vegetarian options, and Fair Trade coffees and teas.

Their chili, a popular staple, is vegan, delicious and hearty. It's packed with chick peas and beans with a smooth blend of spices and served with crispy corn chips. It is the perfect meal for a cold winter day.

Their chip and dip has crispy and salty corn chips, with hummus and made-in-house salsa. It makes a great light and refresh-

ing snack. Their tempeh sandwich served with specialty home fries is a vegan textural delight where sweet soy tempeh meets crunchy, acidic slaw in a toasty bun. The home fries are a crispy golden brown with a hint of rosemary. The cool sandwich and the warm home fries beautifully complement each other.

Despite rumors, the Grad House does not prepare their high-quality food using a microwave, as that would drastically diminish its quality.

On top of all this amazing food, the Grad House also hosts weekly events that mostly cater to grad students, but can, of course, be enjoyed by all. Trivia and open mic nights happen every other week, and this term, the Friday concert series highlighting local bands and musicians are happening twice per month.

There are also board games in-house for anyone to use anytime they visit the Grad House. Additionally, wine/beer tastings and Writer's Whimsy events happen less often. You can find out about what is going on at the Grad House anytime by checking out their social media pages.



Raymond's Flower Shop

*Beautiful Flowers For All
Life Occasions!*

**University
Students**

Receive 10%

(show ID ; excludes holidays)



PHOTOS CHARLOTTE HINGS

Their tempeh sandwich served with specialty home fries.

133 Weber Street, N., Waterloo
519-886-3830 www.raymondsflowershop.com



Waterloo strike against climate change

Dedicated climate activists come out in the cold to urge change for climate justice.

Harleen Kaur Dhillon
Editorial Assistant

Megan Ruttan is concerned about the world that her now-five-year-old son will live in when he is older. As a member of several environmental organizations in the Waterloo Region including Rise Waterloo, Ruttan is trying to make the world a more habitable place for her son by working against climate change.

Ruttan helped organize the strike against climate change that took place on Feb. 1 in front of City Hall.

She, along with co-organizers Mo Markham and Caterina Lindman, support youth in striking and becoming more involved in the fight against climate change.

"I'm here because of maternal terror," Ruttan said. "Climate change scares the shit out of me."

Sophia Kudriavtsev, a fourth year student in Sexuality, Marriage, and Family Studies at the University of Waterloo, was one of the strikers.

"Today specifically, we're demanding that the Region of Waterloo declare a climate emergency," she said.

"We really need to see governments pooling all possible resources towards this because this is something that is threatening our future. It's threatening our everyday lives, and we really need to take it seriously."

Among the strikers, the general consensus was that climate change is a matter requiring urgent attention.

"I see the impacts of climate change everyday and what I don't see from our government is serious action ... and recognizing that we need to take action now, or else we're not going to have a chance," Kudriavtsev said.

"It's our future and at the end of the day, our education doesn't really mean much if we don't have a planet to live on," she said.

Jodi Koberinski is a Ph.D. student at UW and was present at the strike.

Other strikers confirmed that she is present at most of the strikes and continues to show her support. Koberinski has been working against climate change since the 1980's, and she recognizes the urgency of the situation as well.

"What folks are starting to realize is that it's not about picking a better strategy or coming up with some new engineering or some other way around the problem. At the root of the issue is global corporate capitalism that commodifies life at the expense of all other values. Students around the globe, who are teenagers get this stuff," she said.

Maddy, a grade 12 student in Cambridge, was one of the students present at the strike. She and her friend Shayna are both heavily involved in activism against climate change.

"It's our generation now — we're the ones that have to fix it now," she said.

In particular, strikers were concerned about recent advances in fossil fuel infrastructure, namely Bill 66 and pipelines.

"Our country is still going ahead with fossil fuel infrastructure in a really big way, including the pipe-

line that we just bought. We're going in the exact wrong direction for this. We need to rapidly start turning this around and we have ten years to do that," Ruttan said.

"Justin Trudeau and the government are kind of passing Bill 66 to do the billion dollar pipeline so you know, today, that doesn't matter, it's not doing anything to me today," Shayna said. "But once that's built and we're investing in the fossil fuels, and we're going through the Arctic, and we're doing this and that, then we're going to see [major consequences]."

Strikers recognize the need for action at any and all levels. They also stated that people can no longer rely on government leaders to listen to their concerns. They have to make themselves heard.

"The ground level desire for climate action is not being addressed by the government, the leaders

are not doing very much about the emissions which keep rising. So, the only way to counter that is to be more disruptive," Ruttan said. "We don't have an allowable amount of warming, we need to stop emitting now. I don't think our leaders realize that."

"The one thing that I really want to see is this happening on an international level. Municipalities are talking more about what we can do," Kudriavtsev said.

"We need to see all the world leaders coming together and making sure that we come up with an economic structure and policy that's going to keep us in line with what the environment needs."

Koberinski stated that there needs to be a change in the way that we view climate change and its possible solutions.

She recalled some of the words said to her by Dr. Vandana Shiva,

a board member of the International Forum on Globalization and activist for many causes.

"It's not about winning. The outcome isn't about saving the planet or making it hospitable for humanity. It's the minute you know there's an injustice and there is suffering, it is your job as an able-bodied person to do something about that suffering and injustice," she said.

The School Strike for Climate is modeled after the efforts of Swedish student Greta Thunberg, who protests outside government buildings regularly. This strike will take place on the first Friday of every month.

An information session against Bill 66 hosted by Grand River Environmental Network, in conjunction with other environmental organizations, will take place at the First United Church on Feb. 7.



A renewable future is possible, we just need urgent action.

PHOTOS HARLEEN KAUR DHILLON

UW is disappointed in the Ford government

Feds joins 75 Canada-wide institutions to express dissatisfaction with OSAP changes

Harleen Kaur Dhillon
Editorial Assistant

Students across Ontario are concerned about the effects that recent changes to OSAP will have on their education.

In addition to changes in tuition structure, the Student Choice Initiative allows students to opt out of many ancillary fees, including the fees that fund student unions.

On Jan. 29, Feds President Richard Wu signed a letter along with 75 other post-secondary institutions from across Canada, expressing the disappointment of students in the changes made to OSAP.

The Ford government announced several changes to OSAP in mid-January.

These include a 10 per cent reduction in tuition, a mandatory loan to grant ratio of 50 per cent, the removal of the six-month

grace period, and the Student Choice Initiative.

Matthew Gerrits, current VP of Education who is also running for re-election, has taken the lead on addressing the changes for Feds. He emphasized the detrimental effects that the Student Choice Initiative may have on student unions.

“Most universities depend on student unions who were funneling the student voice to them on lots of different committees,” he said. “[Student unions] as a sector stakeholder across the entire country see this is something that is potentially harmful.”

In particular, student unions are concerned about the lack of funding stability that may occur when Feds fees are not mandatory, and the effects that this instability will have on the short and long-term function of Feds.

“How do we budget for staff when we don’t know if we are going to see 100 per cent of our fee

collected or if we’re going to see 20 per cent, how are we going to try and invest in long-term projects?” Gerrits said.

“Suddenly, a lot more of our efforts will be less focused on providing services and there’ll be a lot more trying to figure out.”

The letter that Wu signed stated, “Without stable, predictable funding student unions will be forced to end a wide variety of programs and services ... undermining the protection and creation of jobs on campus.

With a 10 per cent tuition cut and no additional public funding, we know institutions themselves won’t pick up the slack.”

Universities will also see a decrease in revenue from the mandatory tuition cuts, so Gerrits is unsure of how they will be able to mitigate the effects of the Student Choice Initiative on student unions.

“[The] university is going to be at a point where they’re going to

have decreased revenue as well. They’re not going to have the ability to take on big, new projects ... I would hesitate to say that there’s any conclusive thoughts of anybody taking anything over, because we don’t know what we are and aren’t going to be able to provide until the government gives more details,” Gerrits said.

The goal of the letter addressed to Premier Ford and Minister Merrilee Fullerton was to encourage the Ford government to do proper consultations with students and then make decisions that would be beneficial to all key stakeholders.

“We urge this government to sit down with student associations — as well as administrations, labour groups and business networks — to better understand how these changes will create a workforce less prepared and saddled with debt,” the letter stated.

“If postsecondary affordability is the government’s top concern, there are better avenues to ad-

dress this. Many of those avenues have been advocated by the very student associations signing this letter.”

In the letter, student unions from across Canada expressed their disappointment in the Ford government’s decision, and stated that the changes will be harmful to low and middle-income students. The letter also stated that these changes will affect the ability of students to attain post-secondary education, thereby hindering their prospects in the workforce.

“The government’s recent changes to the Ontario Student Assistance Program (OSAP) are disappointing, to say the least, for students and families.

“While we support the government’s goal in making postsecondary education more affordable in Ontario, the announced changes raise flags for students, families and anyone interested in the province’s ability to stay competitive in years to come,” the letter stated.

WATERLOO JOURNAL
OF ENVIRONMENTAL STUDIES

WJES

Imprint’s newest online academic journal that reflects topics and info regarding environment sciences on campus/community/nationally.

POSITIONS AVAILABLE

MANAGING EDITOR - 22 hrs/week; \$14/hr

Oversees all journal communication between, reviewers, editors and writers. Following team functions given by Executive Editor. Recruit, marketing, chair meetings/workshops. Contribute to Journal content and editing. Strong academic writing background and knowledge of Journal’s focus. Familiar with online design.

CONTRIBUTING WRITERS

Are you working on/or have a finished research paper concerning the environment? Email WJES.

FOR MORE INFORMATION, CONTACT editor@uwimprint.ca

Imprint hosts Feds candidate debate

Harleen Kaur Dhillon
Editorial Assistant

The Candidates' Debate took place in the SLC Great Hall on Feb 4. Candidates were asked a number of questions ranging in topics from OSAP to sustainability on campus.

The election begins on Feb 5 at 10 am, and will last until Feb 7 on vote.feds.ca.

HIGHLIGHTS FROM THE DEBATE

Many people were dissatisfied with how the closure of the Bomber was handled. Had you been in the VPOF position at the time, how would you have handled it?

**JOSHUA MBANDI, VP OPERATIONS AND FINANCE
TEAM GOLD**

"I think that the way the Bomber was closed was done terribly... the first thing that I would do is I would make sure that, before the Bomber reached the point of needing to be closed, its business practices, its policies, and the way that it operates were operated in a way that it was both financially viable and worked for students... I would have ensured that the Bomber staff would have had a heads-up or at least would have been sort of -- that they wouldn't have been treated the way they were treated."

**SENECA VELLING, VP OPERATIONS AND FINANCE
TEAM IGNITE**

"The Bomber staff was primarily students... when things change, students have a right to know, I think communication is

paramount. The first thing I would have done differently is start the conversation much earlier... so that we can still inform the staff and have that preemptive conversation. The next thing that I'm going to say, when you're going in there and telling people they don't have jobs anymore, I would go in there with a letter of recommendation and I would go in there with a list of other opportunities within the Federation of students."

In light of the new changes made to OSAP by the Ford government, how will Feds continue to advocate both for the students and themselves?

**MATTHEW GERRITS, VP EDUCATION
RE-ELECTION**

In light of the changes to OSAP, we have to consider that a lot of our students are affected... there are two ways that I want to go. One, we need to talk to the provincial government and make it clear that these changes to OSAP affect not only students in their own ridings, but also a lot of ridings that the conservative MPPs especially, represent all across Ontario.

The Federation of Students under me has already developed a system of sending out emails providing people with the opportunity to send emails to their local MPPs.

The second piece that I would like to highlight is that there is also a lot of federal financial aid that falls under the federal system, and that's something that I think we should be focusing our advocacy efforts on going forward.

**FAYZA IBRAHIM, VP EDUCATION
TEAM GOLD**

This is going to be really advocacy-based. I think we're going to need to understand who this affects the most, this affects the most vulnerable of students, we need to protect them. My team and I, not just as candidates, have been doing a lot of on-the-ground work in terms of getting students to sign petitions or to protest and that is something that we will continue to keep doing. And students united will never be defeated.

Essentially, it's really important to recognize the power that we have as students. Our government fears us because we're the ones that vote them in... if we can continue to advocate for all of these different things, as long as we're here together mobilizing, so I think that's how we can address those issues.

Everybody has mental health as a part of their platform. What will you do specifically to better mental health on campus and why do you think that's the best way to go?

**AMANDA FITZPATRICK, VP STUDENT LIFE
TEAM GOLD**

I think, with a lot of the conversations that we have been having, they've been very focused on predominantly on peer support and counselling and, as amazing as those are... I think what we need to be doing is focusing on more of an upstream approach and trying to focus more on the barriers that are in place and the systemic issues that are actually causing mental health issues because if we wait until the point where people need to go to an emergency counselling appointment, you're too late.

It's great to have a diverse set of counsellors, which is something we are also pushing for.

That's why I'm running for VP Student Life because I want to make sure that student life on campus and campus wellness is ingrained in every part of how our campus runs and that's why I want to create an upstream mental health resource that works on both mental health and student life that will match every single student with all the clubs, services, and resources both on and off campus that can help their mental health.



Left to right: Matthew Gerrits and Team Gold: Joshua Mbandi, Amanda Fitzpatrick, Simran Parmar, Fayza Ibrahim.

**TOMSON TRAN, VP STUDENT LIFE
TEAM IGNITE**

We've been talking about having QPR training for staff, faculty, and student leaders here and that's also multifaceted. Another thing that we've been focusing on in our campaign is multilingual counsellors. A fifth of our university is international students, maybe some of them aren't comfortable enough to talk about their own issues, so we really want them to feel comfortable to go to counselling, to have multilingual [counsellors] so they could really talk about all these issues if they do have them. And overall mental health, again, we want to really support the services we have in societies so that when students are having problems, they can really look up to the student leaders and they can help find resources there.

As a position with few clear-cut responsibilities, how do you view your position as president and how will you support your VPs?

**SIMON GRIGGS, PRESIDENT
C-SOC**

Simon Griggs read from a pamphlet describing the role of the president, as written by Richard Wu. As the chief executive officer and primary spokesperson of the Federation of Students, I would be responsible for representing the undergraduate membership of the University of Waterloo to the University Senate, Board of Directors, and a number of university committees. Within Feds, the president frequently collaborates with and serves as a resource to the other executives and is also responsible for overseeing all aspects of student government including

general meetings, elections, and referenda. Externally, the president frequently advocates, in collaboration with the vice president of education to the provincial and federal governments on undergraduate student dealings. I'd like to thank whoever wrote this. Thanks, Richard.

**SIMRAN PARMAR, PRESIDENT
TEAM GOLD**

I would like to transfer the skills that I have developed over the years as a past service coordinator and exec for various clubs and the overall experience I've gained at the [Grand River] Hospital... as the president, I see the role as someone who brings people together, keeps everyone accountable and on task, making sure that everyone is working at their maximum capacity, they're utilizing their talents. So, as president, I would see myself as someone who would bring my team together and ensure that everyone is utilizing their skills to the maximum ability.

**MICHAEL BEAUCHEMIN,
PRESIDENT
TEAM IGNITE**

Right now, the feds directive functions under a horizontal structure. If Team Ignite is elected, we would like to change that a little bit just to make sure that the VPs report to the president, and that way, you have a direct path of accountability from the VPs to the president to the Board. And then the president can work with each VP individually... I think that lending the position of the president, which has some power and some political sway, to issues that the VPs are facing is a good way to start to help support them.



PHOTOS GINA HSU

Seneca Velling (left) of Team Ignite and Simon Griggs of C-Soc.



WRITE FOR US

Want to write stories that cover events like Donna Strickland's Nobel prize? Email editor@uwimprint.ca and become a science reporter

Converting CO₂ to something useful



COURTESY VERDICT.UK

Recycling CO₂ emissions reduces atmospheric carbon dioxide levels.

Labiba Nahian
Reporter

The utilization of carbon dioxide (CO₂) is beneficial from an economic and environmental standpoint.

Not only is recycling gaseous CO₂ affordable, it also reduces at-

mospheric carbon dioxide levels.

One way that chemists can use CO₂ is by converting it to other compounds. Current studies suggest that these conversions can be performed efficiently in the future, when paired with renewable but intermittent sources of energy, such as wind and solar energy.

However, the electrochemical conversion of CO₂ to carbon-re-

lated products is generally sluggish as CO₂ is a thermodynamically stable compound.

In addition to that, it competes against other processes.

This decreases the formation of desired products.

One interesting product that is a result of these processes is formate. Formate is a stable, non-toxic liquid that has a lot of potential. It can be used in hydrogen carrier systems and formic acid fuel cells.

One major drawback is that the production of formate requires highly active and highly selective electrocatalysts. Based on reports studied in the past, the most common metal-based catalysts (such as silver, gold, and nickel) show a low affinity for formate production.

Furthermore, many complications arise with compounds that

show a high selectivity for formate production, including the cost of maintaining these catalysts, their toxicity and potential environmental drawbacks.

Recent research, however, shows that tin and bismuth are possible useful products as well being cost-friendly and environmentally-friendly in comparison to past alternatives.

Zhengyu Bai, Henan Normal University Professor, said, "It's critical to improve selectivity, activity, and stability of catalysts for CO₂ electroreduction. We reveal the orbital interactions of the bimetallic catalyst, effectively shifting reaction pathways toward formate formation."

Professor Bai, along with Professor Zhongwei Chen of the University of Waterloo, and their co-workers are designing a high-

ly selective electrocatalyst for the conversion of CO₂ to formate using tin and bismuth.

The catalyst consists of tin nanosheets interspersed with bismuth particles.

Interactions between the two compounds facilitate the conversion of CO₂ with a remarkably high efficiency.

Theoretical calculations, outlined in their research, suggests that the high efficiency is a result of the strong orbital overlap between tin and bismuth.

The present research sheds light on the design of catalysts for future carbon dioxide conversion studies by highlighting an efficient and cost-effective synthesis technique for bimetallic catalysts.

For more information on this issue, visit <http://chemeng.uwaterloo.ca/zchen/>.

EXCITED. OPTIMISTIC. CONFIDENT. FUTURE READY.

Get the hands-on experience you need to enter the job market with confidence. In one year or less, a **Mohawk Graduate Certificate** could help you:

- Gain workplace experience
- Make connections in your field
- Increase your employability
- Advance your career

APPLY TODAY!

"I am enhancing my problem-solving skills and other competencies so that I will be successful in the real world."

Olusola
Business Analysis
graduate student



mohawkcollege.ca/gradstudies

MOHAWK
COLLEGE

Donna Strickland delivers guest lecture

Nick Owens
Science and Tech Editor

The first University of Waterloo President's Lecture of 2019 happened on Wednesday, Jan. 30. The speaker was Waterloo's own Nobel Laureate, Professor Donna Strickland. The topic of the lecture was, on the very subject which led to her being the third woman in history to hold this distinction.

Chirped Pulse Amplification (CPA) as a means of creating high intensity lasers has become an important part of modern society. However, lasers themselves were only invented in the 1960s, and this method of amplification was not discovered until the 1980s. This was, when Professor Strickland dedicated her Ph.D. thesis to experimenting on the subject.

Professor Strickland mentioned how CPA was originally only one part of her idea for a Ph.D. thesis. The other part involved trying to find a way to twice ionize nickel (something which has since been deemed impossible). However, doing so would involve the use of a powerful laser which could emit short pulses of light, something which could not yet be done.

To help iterate why, Professor Strickland explained how light comes in pulses, with laser light being no exception. The energy from a one-second pulse of laser light is contained in a beam that stretches a very long distance due to the high speed of light.

By shortening the pulse of light, the same amount of energy creates a much denser and more powerful pulse. However, with a standard laser design, the density of energy ends up drilling holes in the material used to amplify the laser. For this reason, lasers of the time only created long pulses.

The solution, as Professor Strickland put it, was "so simple, you'll wonder why I got a Nobel Prize for it." Her method involved using optical fibre to cause the light to "stretch" into many different colours. Light comes in a range of colours between red and violet, with red light traveling faster in optical fibre than violet. This would mean, that after passing through the optical fibre, each colour can pass through the laser amplifier at a different time, causing it to act like a longer pulse of light.

Once through the amplifier, the light is passed through another device, only this time violet light travels through fastest and red travels slowest. The result allows the different colours to be put back together into one powerful short pulse of light.

Traditionally, lasers are thought of as something that burns material, but the result of CPA has turned out to be quite con-



NICK OWENS

Professor Strickland speaking about her research on CPA.

trary to this. Because the light is still low in energy but high in intensity, it generates a lot of force without producing a lot of heat. During the lecture, Professor Strickland referred to it as her "laser hammer." This simple fact led to the possibility of CPA lasers being used for applications not heard of before, the most distinctive being laser eye surgery.

These practical applications of her research are what led to her being awarded the Nobel Prize in Physics. The lecture concluded with a description of the Nobel Prize ceremony, and the moment where Professor Strickland went from, as she said, "[a physicist] just trying to do a great Ph.D., and somehow, [landing] in the middle of a fairy tale." The ceremony saw her meet with the King of Sweden as well as the rest of the Royal Family. Nobel's will specified that physics be awarded first, and so Strickland did not receive any lack of attention while in Stockholm, nor has she received any lack of attention since.

In a fireside chat after the lecture, she mentioned some of the advantages of having won the Nobel Prize, including using the moment to state how important it is to encourage people to do what they love. She mentioned her belief that a big reason why the percentage of women in physics has not risen, as much as in other fields, is because of how people are encouraged to go into specified fields, of which unfortunately does not include physics. This can lead to discrimination in certain fields lasting longer than others.

She put a final emphasis on how encouraging people to do what interests them, not just what would make a lot of money, would make the world a better place for everyone.

Be a Pilot!

Unique. Adventure. Excitement.



Integrated Airline Transportation Pilot Program

Who is it for?

- Graduates from ANY university or college program
- International students seeking a fast, but comprehensive route to airline flying

Full-time 18-month program, includes the following:

- 750 classroom ground school hours
- 205 aircraft flying hours
- 50+ simulator training hours (fixed base)

Program begins
January 13, 2020



Visit wwfc.ca/integrated-atp for more information or to apply today!

**Waterloo Wellington
FLIGHT CENTRE**

Waterloo Wellington Flight Centre
3-4881 Fountain Street North
Breslau, ON N0B 1M0
T: 519-648-2213 | E: info@wwfc.ca
wwfc.ca

WWFC's program is approved by Transport Canada and approved as vocational programs under the Private Career Colleges Act, 2005 (#105919).

arts & life

WRITE FOR ARTS AND LIFE
Imprint is looking for arts writers! For more information, email art@uwimprint.ca.



WWW.UWIMPRINT.CA
Keep up with the latest trends on campus and community news online.



Commemorating Québec Mosque Shooting

COURTESY THE CIRCLE

Approximately 180 members of the community gathered at Kitchener City Hall to come together and show their respects.

Sarah Mazen
Reporter

Tuesday, Jan. 29, 2019 marked the two year anniversary of the Quebec City Mosque shooting. The shooting took the lives of six innocent men in their place of worship: Mamadou Tanou Barry, 42; Abdelkrim Hassane, 41; Khaled Belkacemi, 60; Aboubaker Thabti, 44; Azzeddine Soufiane, 57; and Ibrahima Barry, 39. On Jan. 29, 2017 gunman, Alexandre Bissonnette, 27 at the time, entered the Islamic Cultural Centre Mosque of the Saint-Foy region of Quebec City, and shot seven bullets, the injured 19 and took the lives of six in the city's biggest mosque. This past March, he pleaded guilty to six counts of first-degree murder and six counts of attempted murder.

While the tragedy took place hundreds of kilometers away, the incident still resonates with the community of Waterloo. The Waterloo region remembered the mosque shooting victims in Kitchener City Hall. The room was filled with people of different faiths to pay their respects.

"We all need to come together to say your pain is my pain and we stand with you [the families and community affected by the shooting]. The commemoration

was organized by the Coalition of Muslim Women (CMW) who invited community leaders of different faiths and notable people within the community to join them. The CMW of Kitchener-Waterloo is a federally incorporated not-for-profit organization with the vision of a community where Muslim women are recognized as leaders to enhance communication and understanding between themselves and the larger community and actively participate as leaders.

Members of the CMW, Imam Kabbar from the Islamic Centre of Cambridge, Pastor James Brown, Kitchener Centre MPP Laura Mae, and Kitchener South-Hespeler MP Marwan Tabbara are a few of the speakers who honored the victims and first respondents of the shooting.

Islamophobia has been a rising issue around the world. The gathering was an opportunity to address the issue, and for the community of KW to congregate and overcome it together. Fauzia Baig, the director of community engagement and outreach addressed the fact that all the individuals who attended the event were breaking down barriers together by simply attending.

"We're putting ourselves out there for you to come and meet and get to know us," Baig said.

Kitchener Centre MPP Laura Mae joined to pay her respects and

gave a compelling speech on the topic of Islamophobia and western media.

"When there's a news story or report of somebody who says they are Muslim, that claims that tradition and especially uses that as a rationale to harm, innocent Muslims that are actually living Islam in the way that it should be lived with love, compassion, and care; are targets," Mae said.

Kitchener South-Hespeler MP Marwan Tabbara attended the memorial and brought a letter written by Prime Minister Justin Trudeau to honor the victims.

Various religious leaders lead prayers throughout the commemoration. Imam Kabbar began his prayers by apologizing for those individuals who have used Islam as an excuse to harm others.

"I want to say to people around me that any person who did something bad, doesn't represent me or Islam. And if somebody did something like that I want to apologize for people in fear. Our job is to try our best for good people to come together and work together to try to stop [violence and Islamophobia]" he said.

Following Imam Kabbar's address Pastor James Brown from the Christ Evangelical Lutheran Church of Waterloo lead a Christian prayer stating that it was an honour for him to be invited to such an important event.

"Regardless of anyone's faith it is everyone's responsibility to care for others," he said.

Commemorations were held across the country. Commemorations, vigils and lectures were hosted throughout the week of Jan. 28 from coast to coast to address the issue of hate, violence, and Islamophobia in Canada. Documentaries directed by students across Canada, as well as various organizations, discussed hate crimes in Canada and how families and both religious and ethnic communities are directly impacted. This was done by filming the

lives of the family of the men who lost their lives and the rehabilitation of the injured individuals that day.

People of all different faiths and backgrounds came together to honor the victims who were affected by the incident. The National Council of Canadian Muslims are asking for Jan. 29 to be designated as a national day against hate and intolerance. Canadian Heritage Minister, Pablo Rodriguez stated that the federal government is still in discussion to identify an acceptable way to honor the victims and their families.



COURTESY THE RECORD

Local religious and civic leaders and members of the public listen to speakers.

Community quilt project at Conrad Grebel College

A grassroots community project is a fun stress reliever for students, staff, and faculty

The warm, fuzzy quilt begins its journey in the fall semester when the project organizers call in donations for fabrics from the college community.

Vyas Anirudh Akundy
Reporter

As part from being glued to books, laptops, and newspapers, you will notice students, staff, and faculty busy quilting when you stroll across the Milton Good Library at Conrad Grebel University College.

“Many Mennonite churches do it this way. It’s a very Mennonite tradition,” Mandy Macfie, a librarian at Conrad Grebel and one of the organizers of this project, said.

During lunch hours and study breaks, this project helps people relax and have a nice chat.

The library, being a major eastern Canadian depository of Mennonite publications and housing the largest collection in Canada of Anabaptist works, is the perfect place for such a traditional activity.

This fun, communal, and calming initiative was started by Mac-



It is really nice to put in a few stitches and have a bit of conversation.

fie and a colleague.

“It’s a fun stress reliever,” Macfie said. “It can be very calming ... It’s a good break from studying. You can step away for 15 minutes and work on the quilt. It just puts you in a different place.”

The warm, fuzzy quilt begins its journey in the fall semester

when the project organizers call in donations for fabrics from the college community. Specifically for this year, in which the third community quilt be made, the donations were to be in shades of yellow, red, and orange.

Next, the fabric was cut into strips and now the quilting began.

“It’s amazing how many people we had come by who had no experience [in] quilting,” Macfie said.

Students who have a bit of free time during the day or are feeling stressed after work can drop by the library any time and contribute as much as they can.

“A journey [the quilt’s journey] of a thousand miles begins with a single step,” goes the famous Chinese proverb.

“It is really nice to sit around the quilt, put in a few stitches and have a bit of conversation,” Macfie said. “I work in the library so I get to see how everyone pitches in to work together.”



Students can drop by any time.



PHOTOS COURTESY UNIVERSITY OF WATERLOO

During lunch hours and study breaks, this project helps people relax and facilitates a nice chat.

ANNUAL GENERAL MEETING 2019

im
print

Wednesday, February 27

10:30 a.m. to 1 p.m.

Multi-Purpose Room, Student Life Centre

For more information

chair@uwimprint.ca or ceo@uwimprint.ca

IMPRINT Publications
Student Life Centre, room 0137 ; 519-888-4048

sports & health



WRITE FOR SPORTS

Want to go to UW games for *Imprint*? You'll be able to talk to players, coaches, and fans! For more info, email sports@uwimprint.ca.



COURTESY JON HALPENNY

Banged up, Warriors fight hard in loss

On Saturday, the women came out much stronger, as they battled hard to keep the game within two points going into the half.

Varun Venkataramanan
Sports Editor

The UW women's basketball team faced the Lakehead Timberwolves in two games on Feb. 1-2 at the PAC. They dropped both games against the number 10 ranked team in the country and moved to a 9-16 record. The Warriors were missing many key players but fought hard to stay in the games.

The women dropped Friday's

contest by a score of 69-45 as they were unable to recover from a strong Lakehead start that put them ahead 35-21 at the half. The Warriors struggled shooting the ball as they shot only 24.6 per cent from the field all game, including a lacklustre 2-18 on three-pointers. However, the Warriors' bench played strong, scoring 22 points thanks to strong ball movement.

On Saturday, the women came out much stronger, as they battled hard to keep the game within two points going into the half (30-28).

However, Lakehead's shooters came out hot, as they outscored the Warriors 24-9 in the third quarter to effectively put the game out of reach. The Warriors were strong on the glass, grabbing 39 rebounds and eight second-chance points. Ella Mahler led the way for the Warriors with 11 points, five rebounds, and two steals in the effort. Forward Hilary Ferguson was strong as well, grabbing a game-high 15 rebounds.

It was also the 20th annual Fantastic Alumni, Faculty, Staff,

and Retiree Day, as UW Athletics alumni were admitted free to the game and packed the stands. The event also featured an Airplane Toss in support of the UWaterloo Wellness Fund, an annual tradition.

The team's next game is on Feb. 5 against the Brock Badgers. They look to play stronger on the road where they currently have a 1-9 record this season. The Warriors currently sit seventh in their division, only two points out of the final playoff spot.



VARUN VENKATARAMANAN

Warriors struggled with the ball.

THIS WEEK IN ATHLETICS AND RECREATION

WARRIORS

im print

W HOCKEY

FEBRUARY 9 VS RYERSON
2:30 PM
CIF ARENA

VOLLEYBALL

FEBRUARY 10 VS GUELPH
(W) 4:00 PM, (M) 6:00 PM
PAC GYM

MEN'S HOCKEY

FEBRUARY 8 VS WINDSOR
7:00 PM
CIF ARENA

SENIOR GAME

M HOCKEY

BATTLE OF WATERLOO BUS TRIP
FEBRUARY 7
7:00 PM
KITCHENER AUD

Purchase your ticket online
gowarriorsgo.ca/battleatthead

VOLLEYBALL

FEBRUARY 8 AT RYERSON

\$10 INCLUDES: TICKET AND TRANSPORTATION

Purchase your ticket online
gowarriorsgo.ca/tickets by February 7 at 1:00 PM

ATHLETES OF THE WEEK

NICK HALAGIAN
HOCKEY

SAMANTHA WARNER
VOLLEYBALL

WARRIORS

Warriors dominate McMaster, remain undefeated

Varun Venkataramanan
Sports Editor

On Feb. 2, the women's volleyball team defeated the McMaster Marauders to remain undefeated. The win brings the Warriors to a record of 14-0 of the season, first in Ontario. The team is currently ranked fifth in the country.

The women began the game dominating the first set 25-19, thanks to quality sets from Claire Gagne, and strong outside hitting from Claire Mackenzie and Sarah Glynn. At one point up 23-14, the Warriors

stumbled closing out the set as the Marauders went on a run to stay in it. McMaster rode the momentum into the second set, where they jumped out to an early seven point lead. The Warriors fought hard but couldn't find a way to break the Marauders' strong defence, ultimately dropping the set by a score of 23-25. However, the women came out much stronger in the third behind pinpoint setting from Katrine Eistrat and a strong service run from Karen Fan, dominating en route to a 25-13 victory. In the fourth, Gagne and hitter Ella Stewart linked up multiple times and helped the Warriors put away the game with a 25-20 victory.

Coach Richard Eddy dug deep into his

lineup for the victory and was rewarded with strong performances by every Warrior that stepped onto the court. Fourth-year Samantha Warner led the game in kills with 19, while Gagne racked up 48 assists to bring her season total to 426, fifth in the province. It was a very strong defensive performance by the Warriors. Sarah Remedios led the way with strong serve returns and a team-high 16 digs on the night. Three other Warriors were in double digits, as Glynn, Mackenzie, and Brooklyn Gallant each finished the victory with 12 digs.

Earlier in the week, the Warriors moved up a spot to become the fifth ranked team in the country because of their dominating

play on the court.

It was also the 20th annual Fantastic Alumni, Faculty, Staff and Retiree Day, as UW Athletics alumni were admitted free to the games (beginning with the basketball games earlier in the day). The event featured an Airplane Toss in support of the UWaterloo Wellness Fund, an annual tradition.

The women will be back in action next Friday for their biggest game of the season as they square off against the defending national champions the Ryerson Rams (12-2) in Toronto.

UW Athletics has organized a bus trip to allow students the opportunity to cheer on their undefeated team on the road.



Ella Stewart (left-top) and Claire Mackenzie (left-bottom) serving against the Marauders. Sarah Remedios (right) who had a game-high 16 digs, prepares to return a serve.



VARUN VENKATARAMANAN

fill a gap

in your program

Athabasca University has over 850 courses to choose from to meet your needs and courses start every month. AU has over 6,600 transfer agreements around the world (including with this institution).

Athabasca University
open. flexible. everywhere.
go.athabascau.ca/fill-a-gap

Warriors take on Winter Invitational



VICTORIA TOUGH

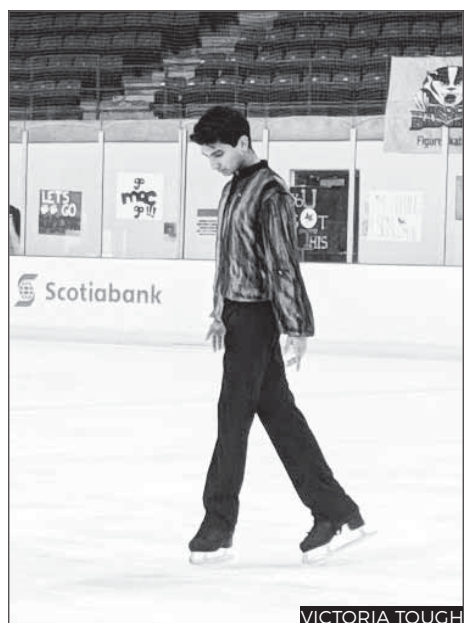

VICTORIA TOUGH

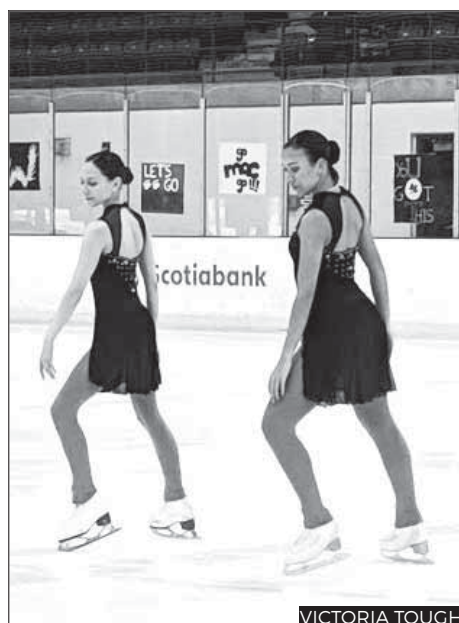

VICTORIA TOUGH



CINDY BRICK



VICTORIA TOUGH



SAMANTHA GOSS



JENNA CROCKER



VICTORIA TOUGH

Collage (left to right): Deanna Gooden, Alex Klem, Roslyn Goodwin, and Jaeleen Koscielski in Novice Dance Fours; group photo; Darshak Patel in Men's Freeskate; Charlotte Hings and Deanna Gooden in Star 10 Dance; Emily Steis and Hannah Chartier in Intermediate Similar Pairs; Synchronized Skating; Emily Steis and Victoria Tough in Rhythm Dance; and Jocelyn Wong in Women's Gold Freeskate.

Charlotte Hings Managing Editor

Coming off a positive note at the Ontario University Athletics (OUA) Fall Invitational competition, the Warriors had been training hard and were confident that they could improve their individual scores and overall placements at the Winter Invitational. On Jan. 29 and Jan. 30, the

University of Toronto hosted the annual OUA Figure Skating Winter Invitational at the Scotiabank Pond in North York, Ontario. In attendance were 10 teams from universities that are part of OUA and McGill University. At the competition, each team sends 1-4 skaters to compete in each of the 14 different events over the course of the two days and depending on the placement of the skater(s) in each event, they can earn points

for their team.

On day one of the competition, UW student, Jocelyn Wong competed in the Women's Gold Freeskate event. She skated a beautiful solo to Josh Groban's "You Raise Me Up," placing fourth, which earned three points for the Waterloo Warriors. By the end of day one of the competition, the Toronto Varsity Blues were leading with 57 points, the Western Mustangs were second with 35 points,

and the McMaster Mauraders were third with 26 points.

On day two, the Warriors picked up the pace, with Deanna Gooden and Charlotte Hings earning three points in Star 10 Dance. Emily Steis and Hannah Chartier in Intermediate Similar Pairs and Darshak Patel in Men's Freeskate earned each one point for the team. The competition ended with the Synchronized Skating event, which was the event that the War-

riors have been training extremely hard for throughout the season. With a strong training foundation and high team spirit, the Warriors skated a fun and entertaining program to Queen's "Bohemian Rhapsody." The Toronto Varsity Blues continued to go undefeated, winning the competition with an overall score of 100 points. The Western Mustangs were second with 79 points and the Queen's Gaels slid into third with 41 points.

Wednesday, February 6, 2019 | Vol. 41, No. 24
 Student Life Centre, Rm 0137
 University of Waterloo
 Waterloo, Ontario N2L 3G1
 P: 519.888.4048 | F: 519.884.7800
 uwimprint.ca

CEO: Andres Fuentes
 Executive Editor: Victoria Gray
 editor@uwimprint.ca
 Advertising & Production Manager: Laurie Tigert-Dumas
 ads@uwimprint.ca
 Editorial Assistant: Harleen Dhillon
 Sales Associate: Mahrukh Latif
 Sales/Marketing Assistant: Pushiti Shah
 Sales/Marketing Assistant: Chantale Madakdze
 Distribution: Alistair MacLellan
 Volunteer Co-ordinator: Gabrielle Myers
 Board Admin Assistant: Yash Sanghavi

Board of Directors

www.imprintpublications.ca | board@uwimprint.ca
 Chair: Verity Martin, chair@uwimprint.ca
 Treasurer: Nikhar Dhingra, treasurer@uwimprint.ca

Secretary: Joe Giuffre, secretary@uwimprint.ca
 Member-at-large: Ben Paul
 Member-at-large: Jacky Brule
 Advisory Member: Lucas Dunlop
 Advisory Member: Vacant
 Advisory Member: Vacant

Editorial Staff

Managing Editor: Charlotte Hings
 Creative Director: Gina Hsu
 News Editor: Suhani Saigal
 Assistant News Editor: Vacant
 Arts & Life Editor: Samantha Mirandola
 Science & Technology Editor: Nick Owens
 Sports Editor: Varun Venkataramanan
 Satellite Campus Editor: Vacant
 Opinions Editor: Vacant
 Distractions Editor: Vacant
 Head Designer: Vcant
 Assistant Head Designer: Vacant
 Photo Editor: Vacant
 Assistant Photo Editor: Vacant
 Graphics Editor: Vacant
 Assistant Graphics Editor: Vacant
 Copy Editor: Ashley Nicolas
 Assistant Copy Editor: Anoja Parameswaran
 Assistant Copy Editor: Alice Sandiford
 Video Editor: Vacant

Production Staff

Bayley Esteves
 Joshua Goldschmidt
 Rhiana Safieh
 Ruth Stewart-Patterson
 Anne Lytle
 Pauline Chung

Imprint is the official student newspaper of the University of Waterloo. It is an editorially independent newspaper published by Imprint Publications, Waterloo, a corporation without share capital. Imprint is a member of the Ontario Community Newspaper Association (OCNA). Editorial submissions may be considered for publication in any edition of Imprint. Imprint may also reproduce the material commercially in any format or medium as part of the newspaper database. Web site or any other product derived from the newspaper. Those submitting editorial content, including articles, letters, photos and graphics, will grant Imprint first publication rights of their submitted material, and as such, agree not to submit the same work to any other publication or group until such time as the material has been distributed in an issue of Imprint, or Imprint declares their intent not to publish the material. The full text of this agreement is available upon request. Imprint does not guarantee to publish articles, photographs, letters or advertising. Material may not be published, at the discretion of Imprint, if that material is deemed to be libelous or in contravention with Imprint's policies with reference to our code of ethics and journalistic standards. Imprint reserves the right to edit, condense or reject any contribution. Imprint is published every Friday during fall and winter terms; and every second Friday during the spring term. Imprint reserves the right to screen, edit and refuse advertising. One copy per customer. Imprint ISSN 0706-7380. Imprint CDN Pub Mail Product Sales Agreement no. 40065122.

Next scheduled post-mortem meeting:

Wednesday, Feb. 6 at 2:30 p.m.
 Imprint Office, SLC 0137

Next scheduled board meeting:

Thursday, Feb. 7 at 5:30 p.m.
 Imprint Office, SLC 0137

opinion



HAVE YOUR SAY

Submit your letter to the editor or your community editorial to opinion@uwimprint.ca. Find more opinions at uwimprint.ca.

Corrupted student unions

It's time they lost their funding

I finished my undergraduate degree as a student in the fall of 2018 and I'm happy that Doug Ford is giving students the option to opt out of student union fees.

Student unions have done nothing but waste and mismanage student funds for far too long.

They're bloated and inefficient institutions that run deficits and have virtually no oversight.

Student unions aren't real democracies.

Supporters of student unions like to parade the fact that all decisions are made via a democratic framework.

If you were to believe them, you would think that every decision and how every penny is spent is decided upon by the student body, but this is far from the case.

Election turnouts at the University of Waterloo's student government were so abysmally low that their results would never be accepted by the general public in a national election.

In 2015, the Federation of Students (FEDS) election turnout was less than 5 per cent. A year later it was only 9 per cent.

Imagine if a prime minister or an MP

was elected by less than 5 per cent of voters, would we still claim that they represent the interest of Canadians?

Yet student union representatives brazenly claim that they are speaking for the voice of all students, when a majority of who they represent didn't participate in electing them.

The lack of interest in student government, emboldens "elected" representatives to believe they can get away with anything and engage in frivolous spending.

Student unions are plagued by corruption.

At best, student unions are extremely inefficient, and at worst, they're participating in the downright theft of student funds.

In 2016, the Ryerson student union ran a deficit of nearly \$1 million dollars. In 2014, Concordia ran a deficit of \$330,000 which they shadily tried to cover up. Or take University of Ottawa for example, who also had a financial crisis of their own, running a \$514,461 deficit in 2016.

Really, what do we expect when putting young and inexperienced people in charge

of millions of dollars?

While running deficits might simply be a case of inexperience and financial illiteracy, some student union representatives have simply opted for defrauding their student body.

Last year, the University of Ottawa launched an audit into their own student union after it was revealed that elected officials were defrauding student funds for personal pleasure.

A report by the student paper Fulcrum, detailed how student union president Rizki Rachiq, spent \$20,000 of student funds on hair salon visits, Audi repairs and Louis Vuitton shoes.

Student union fees are ending up in the pockets of executives

Student union fees are forced upon every student whether they like it or not.

A lot of students don't use the services managed or implemented by their student unions, while executives pocket money and make exorbitant salaries.

In 2011 and 2012, a 35-year old McMaster student union executive, Sam Minniti, made a six figure salary averaging about \$125,000 a year.

After he was dismissed, instead of apologizing, he sued the university for \$500,000 alleging wrongful dismissal.

Students are fed up with their unions

Claiming that the Ontario government's move is an affront to students is simply untrue.

Students have expressed a desire in the past to get out of paying student union fees.

In 2012, the University of Guelph stopped collecting fees for their student union after students voiced their opposition in a referendum.

At the University of Guelph, students overwhelmingly voted against being charged student union fees.

If left alone, student unions just become entitled cliques serving the interest of the few while wasting the money of the many.

Personally, I thank Doug Ford and the provincial government for taking the step to empower students throughout Ontario, I only wish he had done it sooner.

ORIGINALLY PUBLISHED ON THE POST MILLENNIAL.

Cosmin Dzsurdzsa

English literature,

Prospective Spring 2019 graduate



COURTESY AOL.COM

Almost all student unions spend money recklessly with no regard to the students they claim to be representing.

campus bulletin

WHAT'S HAPPENING AROUND TOWN

Submit your 30-word announcement or upcoming event to ads@uwimprint.ca for free.

upcoming events

Wednesday, February 6

UW - Music - Noon Hour Concerts - "Soiree Francaises" with Steven Vanhauwaert, pianist, for more info music@uwaterloo.ca or 519-885-0220, ext 24226.

Wednesday, February 13

UW - Music - Noon Hour Concerts - "Grand Duo" with Jerzy Kaplanek, violin and Leopoldo Erice, piano, at 12:30 p.m., Conrad Grebel Chapel. For more info music@uwaterloo.ca or 519-885-0220, ext 24226.

Tuesday, February 19

Bereaved Families of Ontario Midwestern Region - support group gathering from 7 to 9 p.m. will discuss "Stepping Stones Through Grief," at Westmount Memorial Celebration Centre, 1001 Ottawa Street, Kitchener. For more info call 1-844-437-3247.

Saturday, March 2

Kitchener Comic Con 2019 begins Saturday at 11:00 a.m. and continues until Sunday, March 3 at 5:00 p.m. at Kitchener City Hall, 200 King Street West, Kitchener. Kitchener Comic Con is an award-winning event that celebrates the wonderfulness of all things that are comic book related.

Website: www.kitchenercomiccon.com.
Contact information: info@kitchenercomiccon.com.

extra curricular

HELP - Looking for a knowledgeable person with experience in cryptocurrencies. Please email Lauretta at lanonby@rogers.com with your name, telephone number, best time to call and desired hourly rate of remuneration. Bit of a time-crunch so asap would be helpful.

Thank you UW community for your continued participation in the annual Poppy Campaign. UW's 2018 contribution was \$3,615.00, that contributed to the overall contribution of \$210,313.08.

Gamelan: World Music Ensemble or Community Gamelan - join for credit or as extra curricular. For more information on requirements, rehearsals and concert dates, visit uwaterloo.ca/music/ensembles.

Art\$Pay competition & venue - 2nd performance-based photography event! Submission deadline is Monday, January 28, 2019 by email at info@artspay.org, with event on Saturday, March 2. For more info email Cathy at info@artspay.org or and event info at www.artspay.org.

volunteering

Bereaved Families of Ontario -

Midwestern Region, The Family Centre, 65 Hanson Ave., Suite 1042, Kitchener. We currently have a number of exciting volunteer opportunities. For more info, jaime@bfomidwest.org or 519-603-0196.
Volunteers needed at YOUR student newspaper, Imprint. No experience

needed so come and enjoy lots of new experiences and making new friends! Imprint's office is SLC 0137 or email editor@uwimprint.ca.
Become a Meals On Wheels volunteer! Call 519-772-8787 or www.communitysupportconnections.org/volunteer/apply.

VOLUNTEER at



JOIN THE GEESE.



NEEDED:
section editors
opinion * photo * arts
distractions * head designer
graphics editor * video editor
satellite campus editor

service directory

SPREAD THE WORD

Buy your ad for 1 month at \$99 and get 1 month free! Contact ads@uwimprint.ca.

GENERAL SERVICES

artline SALON

www.artlinesalon.com
678 Belmont Ave W Unit 202 Kitchener
519.585.0230

UNIVERSITY PAIN CLINIC

Highly effective, natural pain relief from:
~ back pain ~ sciatica ~ migraines
~ fibromyalgia ~ neck and shoulder issues ~ stress ... and much more!
Appointment required.

105 UNIVERSITY AVE., E., SUITE B
WATERLOO ; 519-574-0515
www.universitypainclinic.ca

WANTED:
Your Non-working Laptop!

HAS your laptop computer stopped working?
DON'T toss it, sell it to me. I'll buy your broken computer.
FREE transfer of files to your new computer.

logic.repair@gmail.com
text: 519-568-3952



Imprint's arts online magazine that reflects fine arts, photography, poetry and prose by University of Waterloo students, alumni & staff.

POSITIONS AVAILABLE

MANAGING EDITOR

Following team functions given by Executive Editor. Curate content, recruit volunteers, marketing for the magazine and chair meetings. Contribute to content and editing. Familiar with online design.

EDITOR POSITIONS

Photography ; Fine Arts ; Poetry & Prose

Contact editor@uwimprint.ca for more information

distractions



**BELIEVE YOU CAN DO ANYTHING,
BUT NOT EVERYTHING!**

Pre-med is just dead

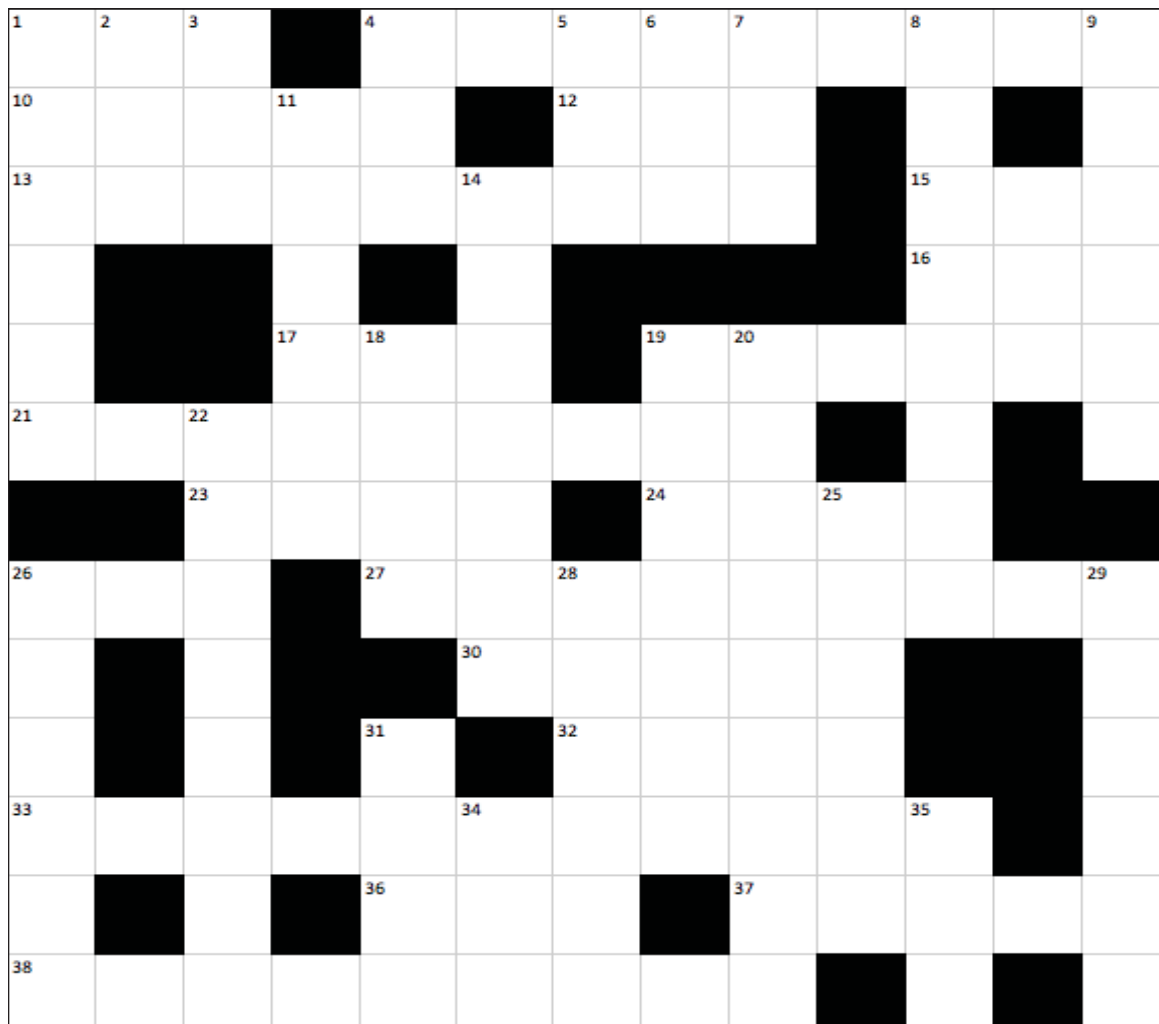

Across

1. Doctor without a thesis
4. Organism created to kill
10. Heals with positive energy conducted through the palm
12. Fish eggs
13. Extract through boiling
15. Singer of "Summertime Sadness" and "Video Games"
16. Brand of cooking spray
17. Female gametes
19. Skrillex sings "I could watch you forever"
21. Zimbabwean, in the early 20 C.E.
23. Host of *The Daily Show*
24. Acidic, tart, or tangy
26. Your sister's husband
27. Wrote *The Shadow over Innsmouth* and *The Nameless City*
30. Earnest in religious observance
32. Netflix competitor
33. Chicken dish marinated in yoghurt and spices
36. Average, especially in golf
37. This dance takes two
38. Criminal with charges laid out upon them

Down

1. Labour or hardship
2. Striped insect with a sting
3. Image, abbreviated
4. Lighter company
5. God-like beings in *Stargate: SG-1*
6. Korean currency
7. Metal disks on the scalp detect brain activity
8. Medical terminology for eyelid
9. Ordinary or typical
11. A non-fictional dragon
14. David's Tea or Teavana
18. Meat from calves
19. Of or relating to cheese
20. To create an immunity, artificially
22. Bystander
25. Antagonist in *The Little Mermaid*
26. To offer a gift
28. Mathematician Victoria Hart, on YouTube
29. A vibration
31. Paternal appellation
34. Homo sapiens
35. A colonial formicidae

Solutions to last week's crossword

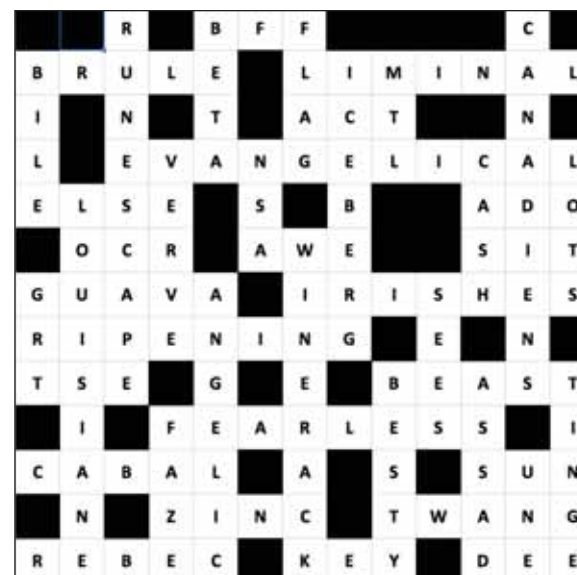

INSERT EXPRESSION *BY TIMI BISH*



SUDOKU

Enter numbers into the blank spaces so that each row, column, and box contains the numbers 1 to 9.

MEDIUM

2	4		9	7	6	3		1
	6	3	5					2
	1		8	2			6	4
3	2	9	6		7			8
4		6		3	8		7	
				4	9	5		
		1				6		
6				8		9	4	
5			7		2			3

COURTESY PRINTABLESUDOKU99.COM

